

Raster Rendering

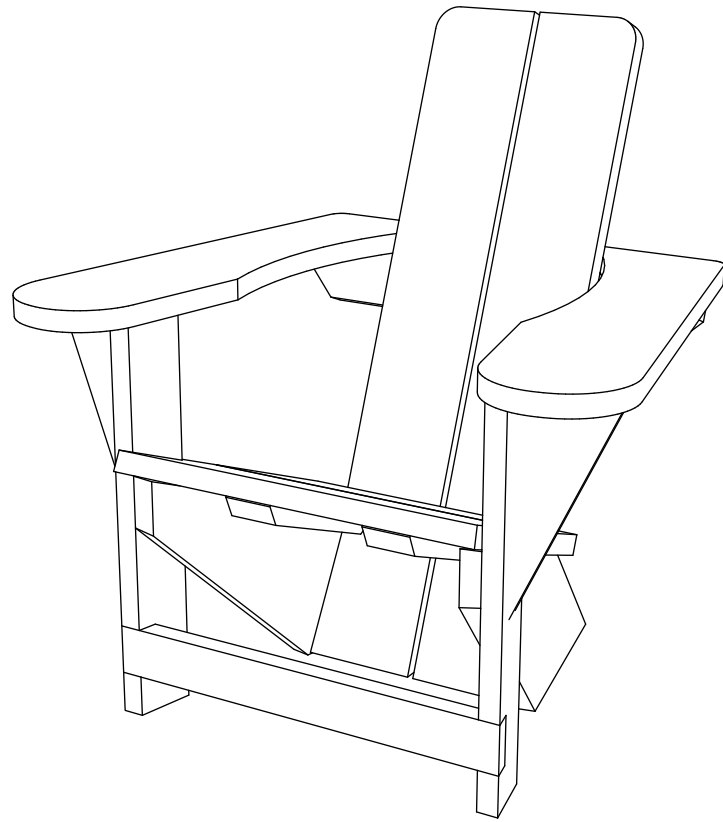

Vector Rendering