

# How to make a simple chair

## Open SketchUp

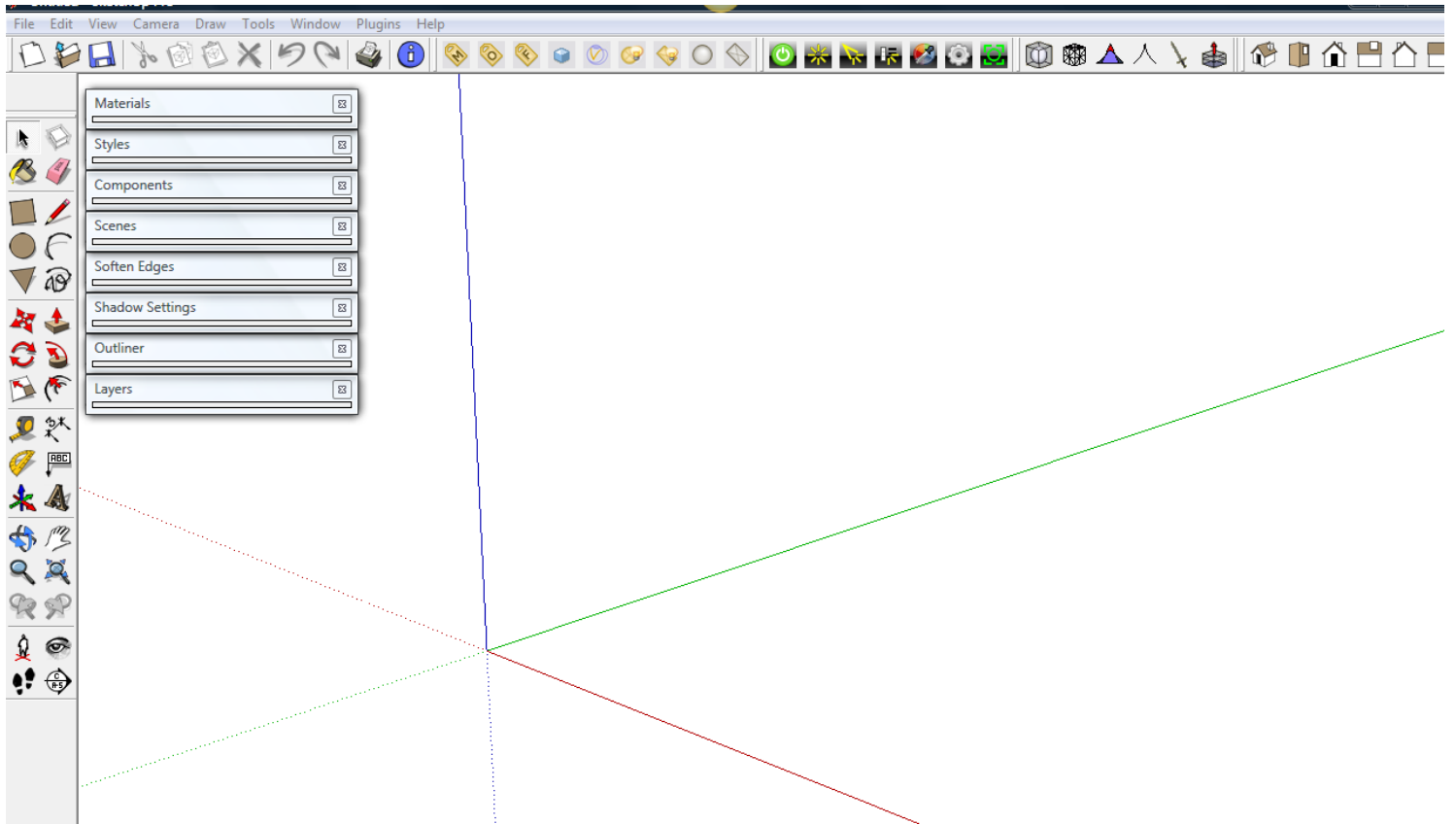

This is what your screen will look like. Make sure it's blank.

## Make a square using the square tool

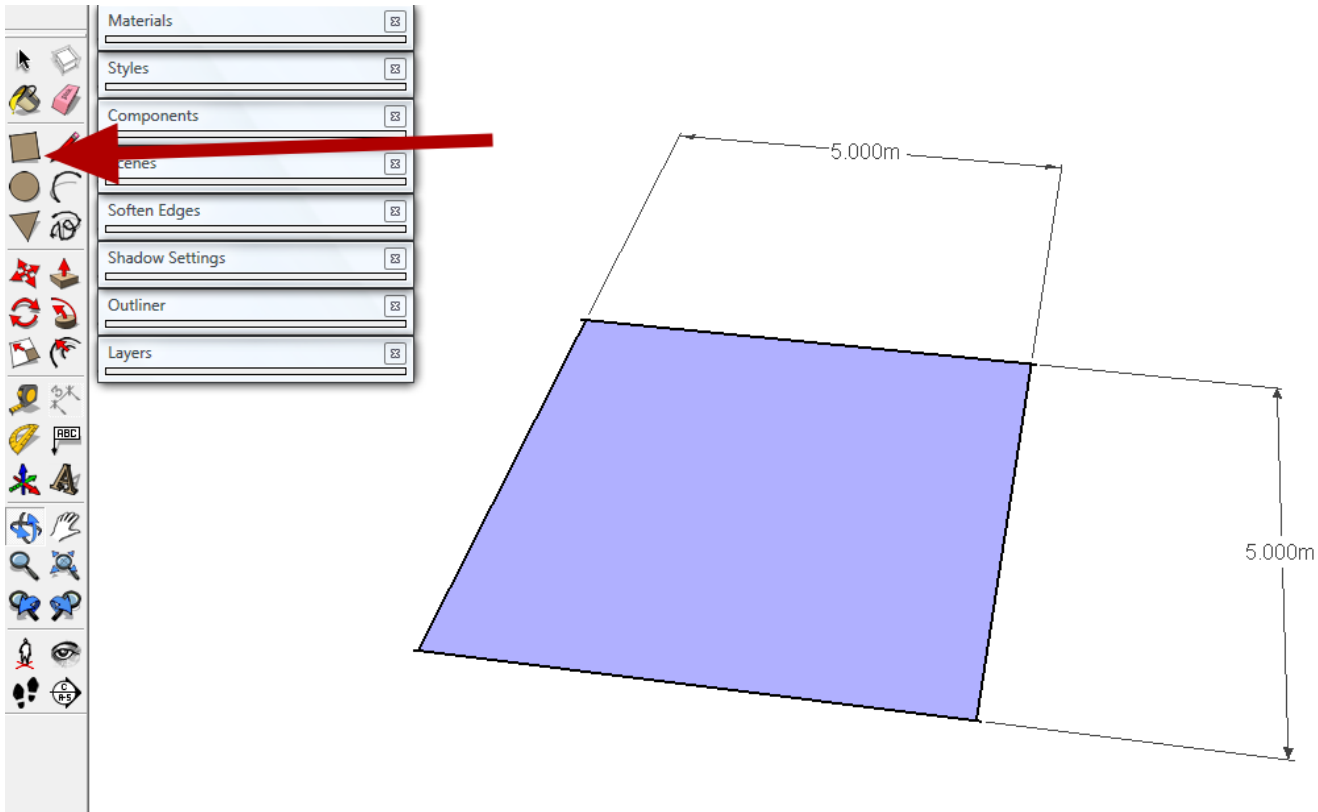

Use the tool the arrow points to. The square can be of any size, but mine is 5m x 5m, because big means you can add more detail.

## Push-Pull your Square

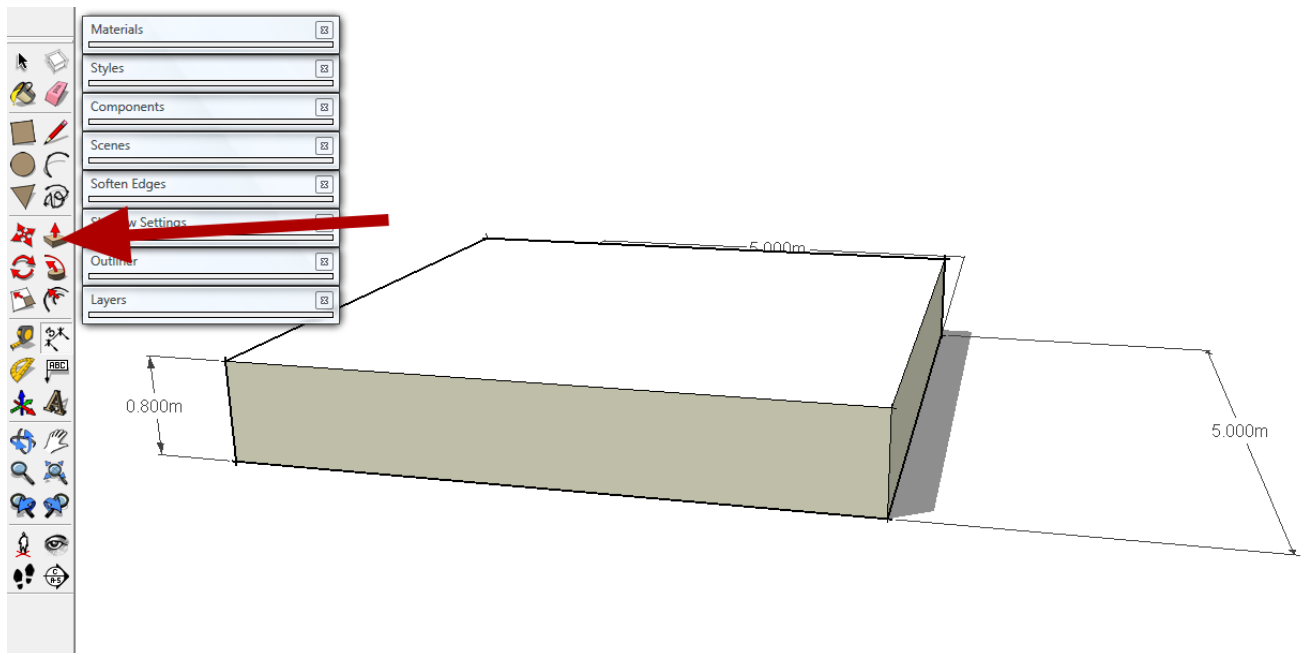

To push-pull, use the tool the arrow points to. You can push pull any distance, but make sure it's not a box.

## Make two Arcs, then push-pull down

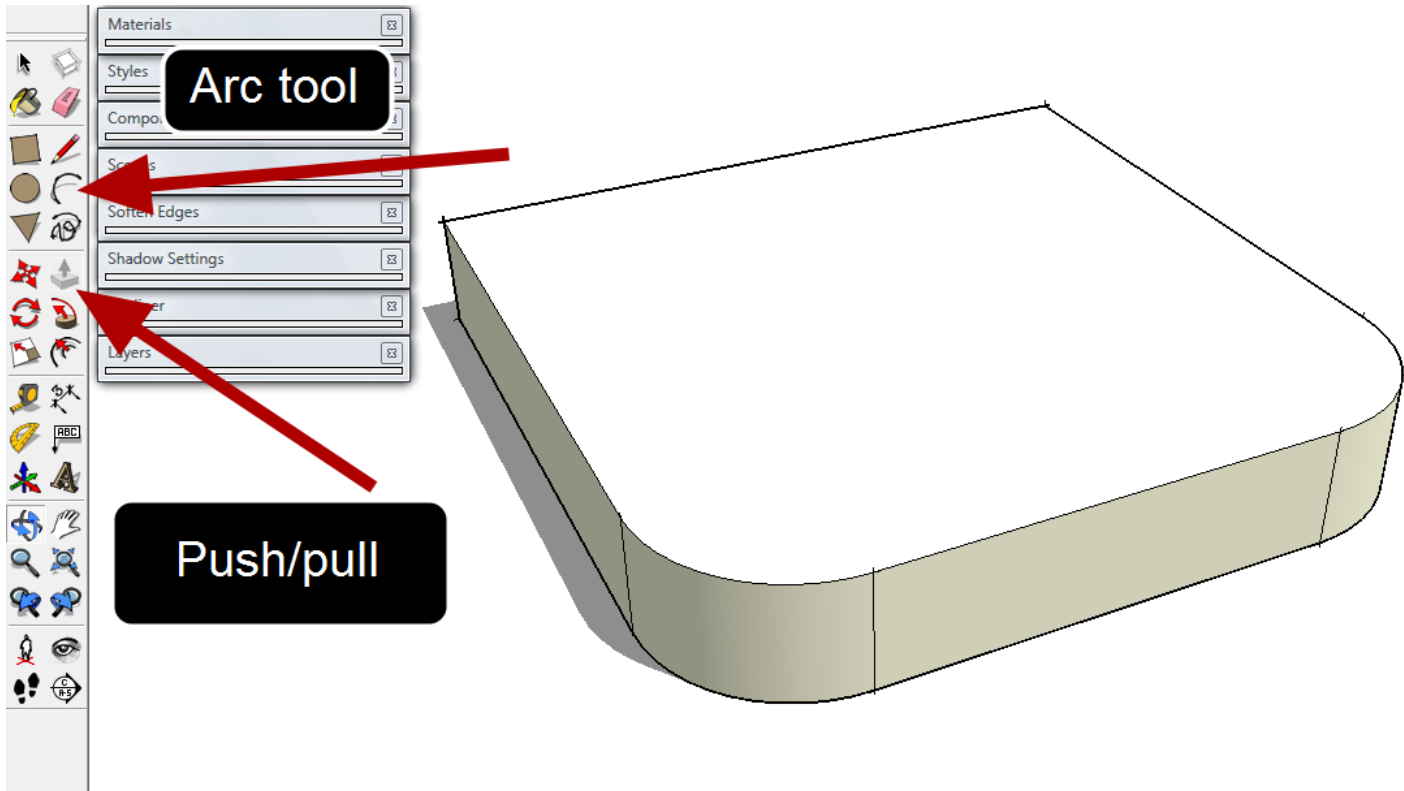

Use the arc tool to make two arcs. Then, copy the arc by using the move tool while pressing Ctrl at the same time. After that, push pull down the two arcs.

## Soften the Edges, and create another arc

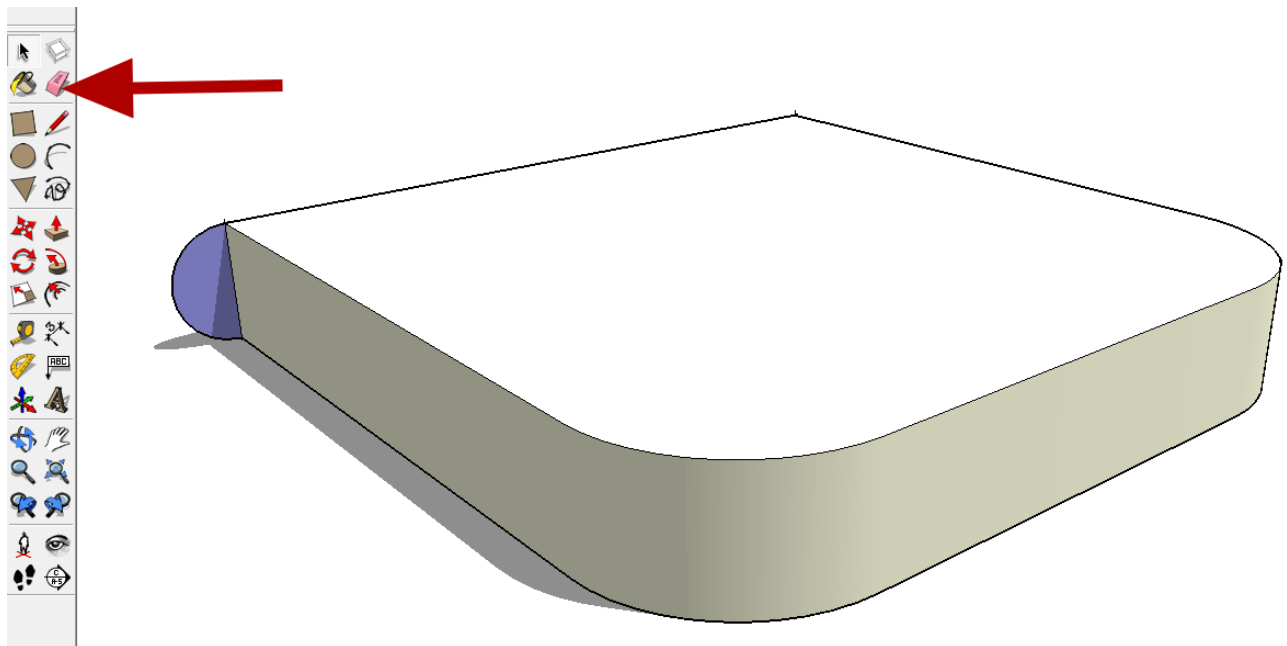

Using the eraser tool plus clicking Ctrl at the same time, click the edges between the arcs and the straight edges.

## Select the Edges

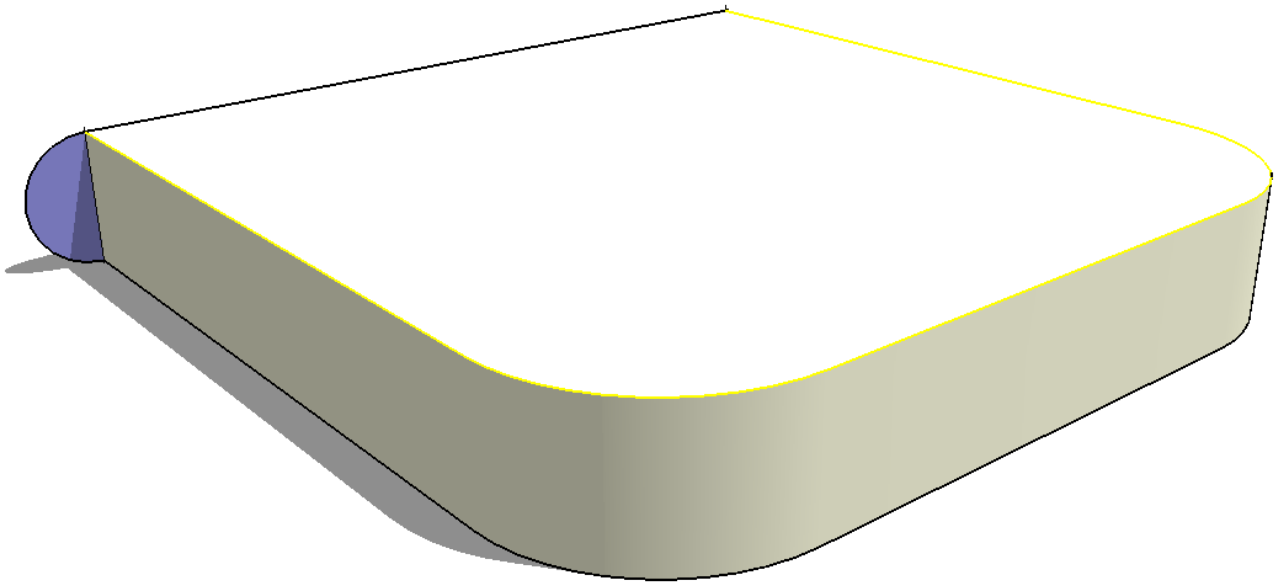

## Then Use the Follow-me tool

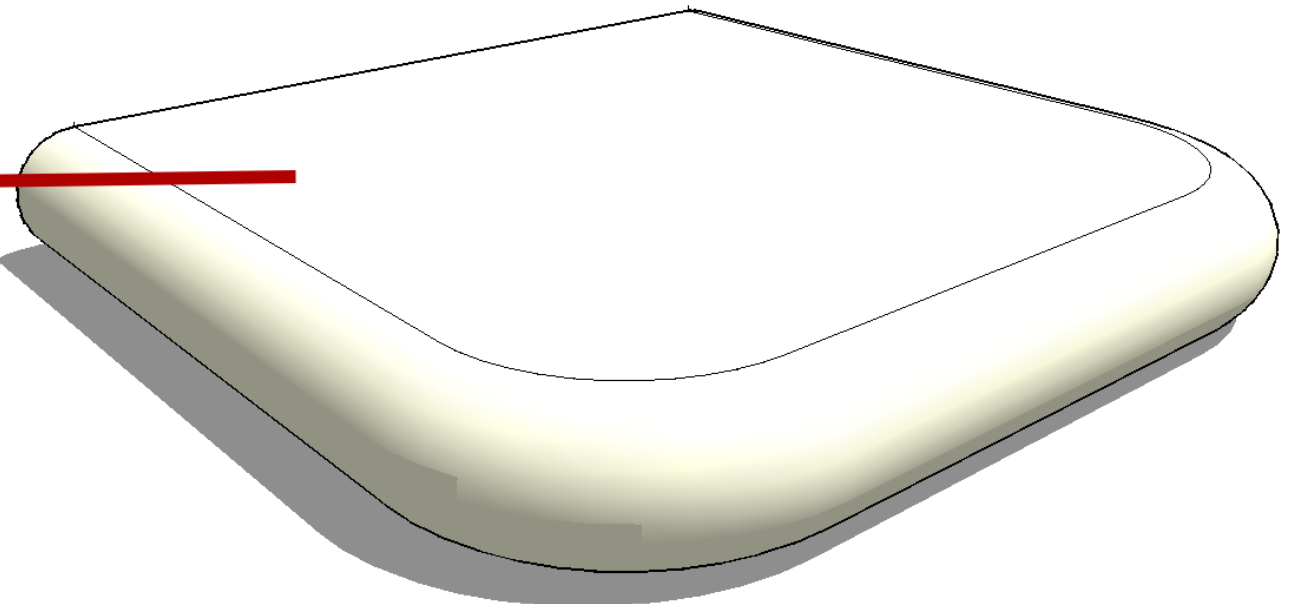

## Erase the back edges, select all, right-click and choose "Soften/Smooth Edges"

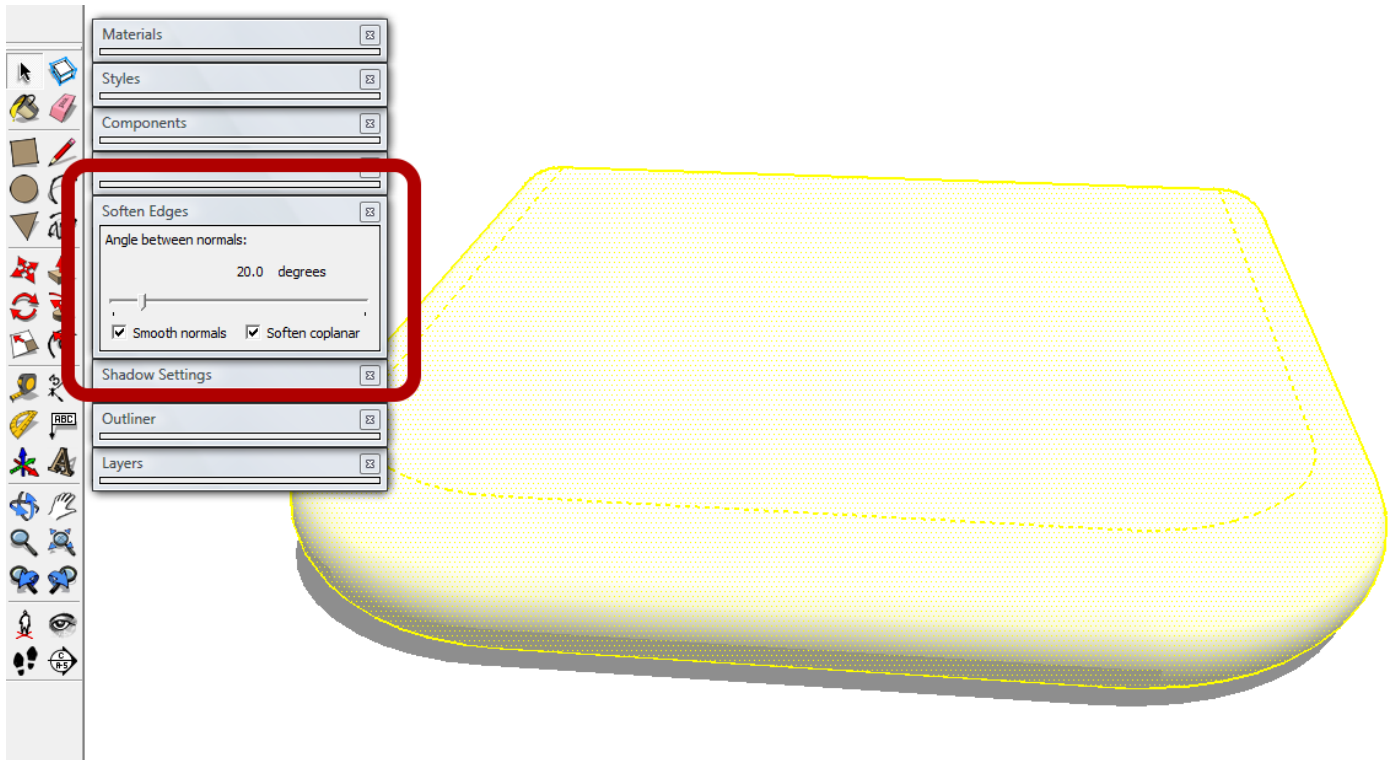

To select all, use Ctrl+A. Make sure you choose "soften coplanar" too.

## Make everything a Group

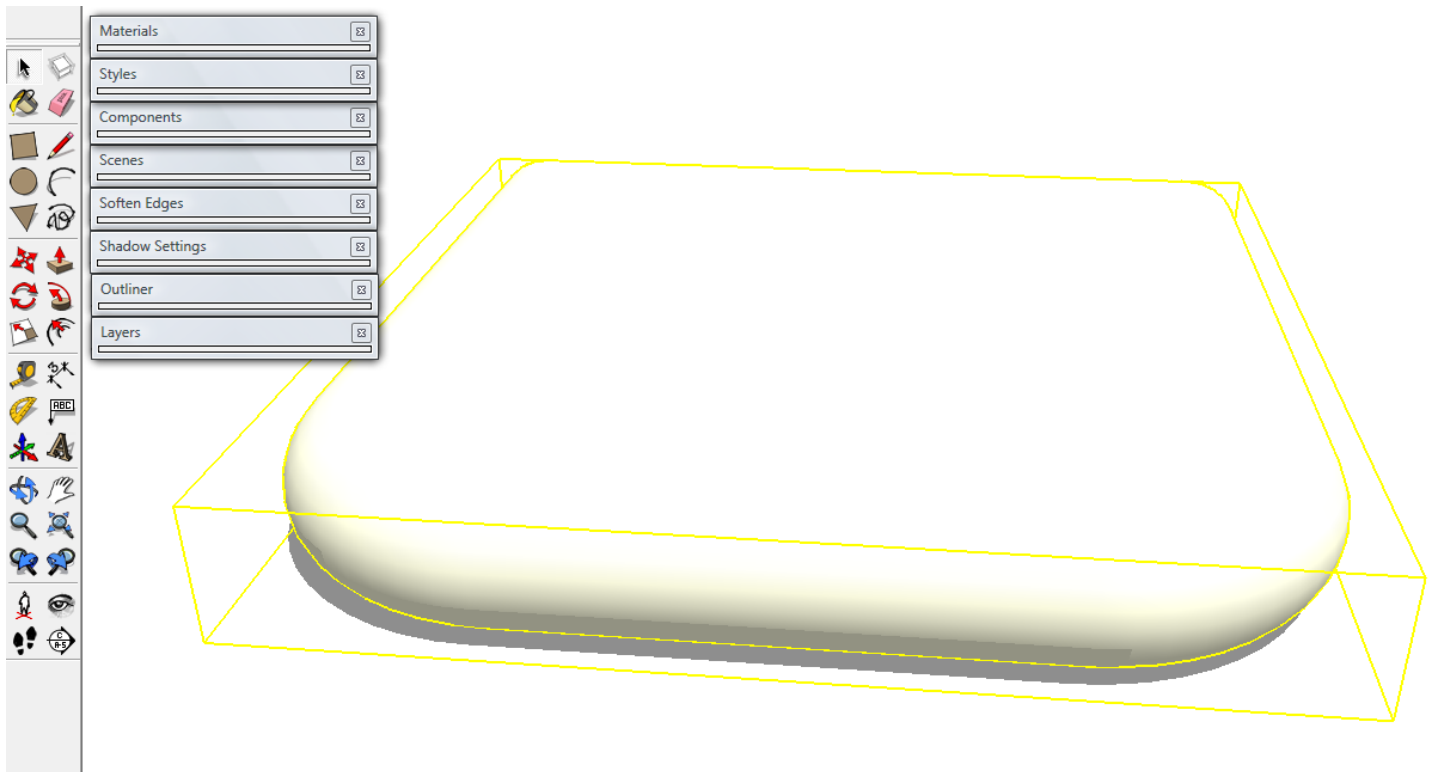

To do this, right click and choose "Make Group"

## Copy the Group, then rotate

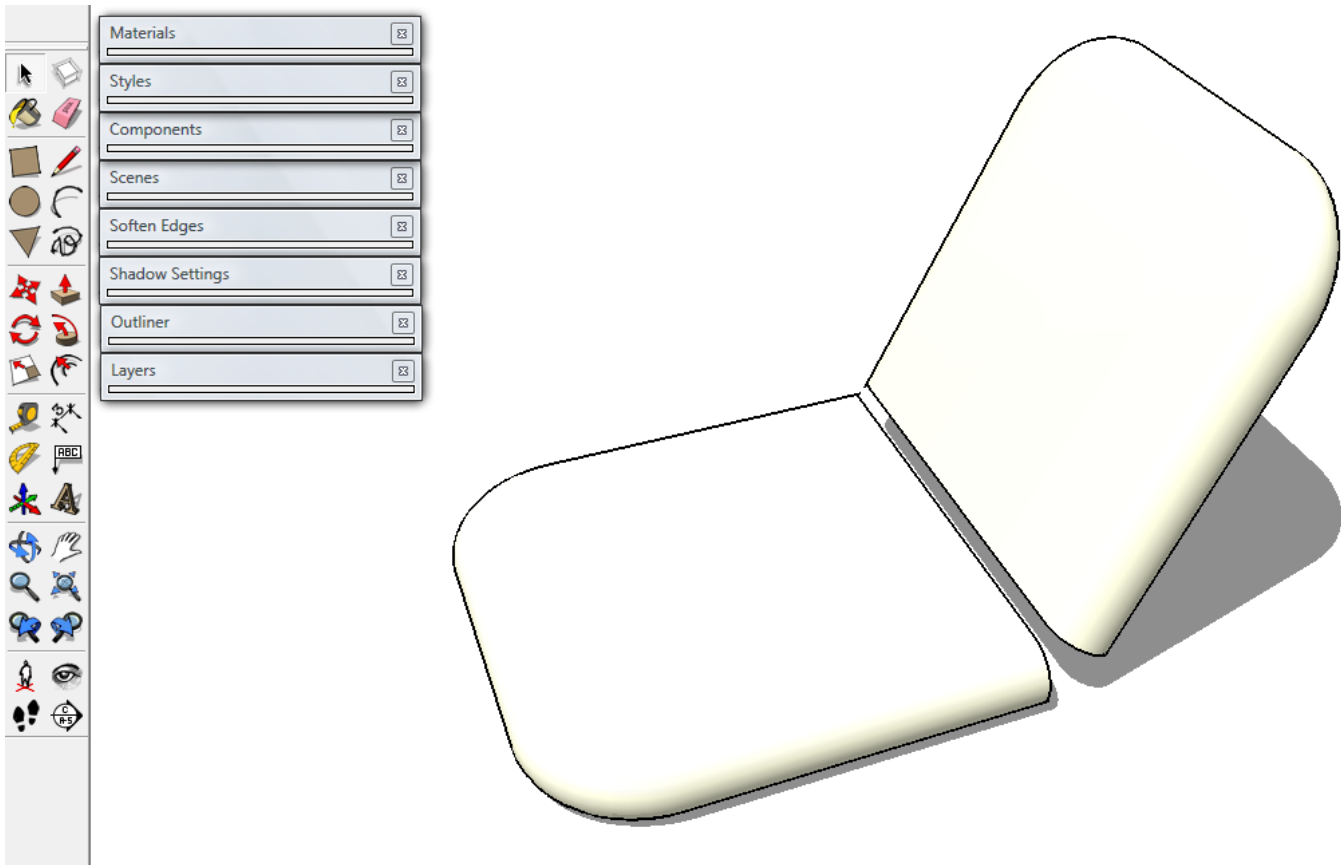

After this, all you need to do is add details. See an example in the next step

## Add Details

