

FREDOSCALE - Plugin for Sketchup

Free Scaling and Other Transformations

VERSION 2.5 – 01 SEP 13

1. Overview

FredoScale applies geometric transformations to a selection.

- For many of them, the selection will be enclosed in an adjustable deformation box. Moving the handles or pads of the box will determine the amount and parameters of the deformation (**‘Box mode’**).
- It is also possible to specify the deformation by matching an origin and a target point. This is called the **‘Target mode’**.
- Finally, some deformations support a third mode, without any box, based on a Protractor. This is the **‘Free mode’**.

FredoScale supports the following transformations:

- **Scaling** (box, target)
- **Taper** (box, target)
- **Plane Shear** (box, target, free)
- **Stretch** (box, target)
- **Twist** (box)
- **Radial Bend** (free)
- **Rotate** (box, free)

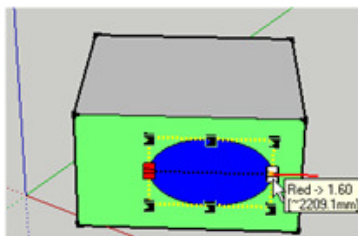

SCALE

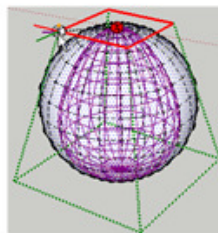

TAPER



PLANAR SHEAR

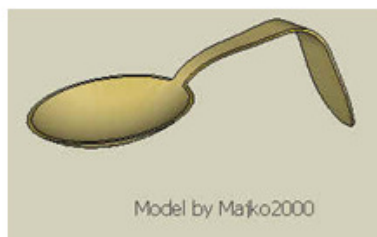

RADIAL BEND



RADIAL BEND

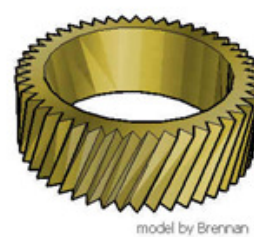

TWIST



STRETCH (before)

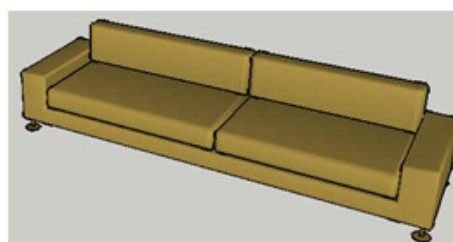

STRETCH (after)

2. Installation

FredoScale supports Sketchup versions 5 (≥ 5.160), 6 and above (Free, Make and Pro) on Windows and on OSX.

IMPORTANT: You need the companion Library **LibFredo6** installed, **v.5.2 or higher**.





Since SU8 M2 and SU 2013, there are now several ways to install a plugin.

- SCF Plugin Store
- SU Extension Manager to install a .rbz file
- Unzipping into the SU Plugins directory from a .zip file





All installations however will end up with the following footprint in the SketchUp Plugins directory:

- one script file *Fredo6_FredoScale.rb*
- one subfolder **Fredo6_FredoScale**. This subfolder contains the library files, the icons, cursor files, language files (please do not alter, rename or move files there).





On Windows, SketchUp 8.0

| Name | Type |
|--|---------------------|
|  C:\program files\Google\Google SketchUp 8\Plugins\ | Plugins Root Folder |
|  Fredo6_FredoScale | Folder |
|  Fredo6_FredoScale.rb | Ruby file |
|  Fredo6_!LibFredo6 | Folder |
|  Fredo6_!LibFredo6.rb | Ruby file |





On Windows, SketchUp 2013

| Name | Type |
|--|---------------------|
|  C:\program files\SketchUp\SketchUp 2013\Plugins\ | Plugins Root Folder |
|  Fredo6_FredoScale | Folder |
|  Fredo6_FredoScale.rb | Ruby file |
|  Fredo6_!LibFredo6 | Folder |
|  Fredo6_!LibFredo6.rb | Ruby file |

On Mac, SketchUp 8.0

| Name | Type |
|---|-----------|
|  Macintosh HD/Library/Application Support/Google SketchUp 8/SketchUp/Plugins | Folder |
|  Fredo6_FredoScale | Folder |
|  Fredo6_FredoScale.rb | Ruby file |
|  Fredo6_!LibFredo6 | Folder |
|  Fredo6_!LibFredo6.rb | Ruby file |

On Mac, SketchUp 2013

| Name | Type |
|---|-----------|
|  ~/Library/Application Support/ SketchUp 2013/SketchUp/Plugins | Folder |
|  Fredo6_FredoScale | Folder |
|  Fredo6_FredoScale.rb | Ruby file |
|  Fredo6_!LibFredo6 | Folder |
|  Fredo6_!LibFredo6.rb | Ruby file |

3. Menus, Toolbar and Configuration

The icons are shown in a toolbar, named “*FredoScale*”¹. By default not all icons are displayed, but you can configure the toolbar to add or remove those you find useful or useless. The Plugin menu entries are located in the Sketchup “*Tools*” menu, under the submenu “*Fredo6 Collection*”:



Since the tools act on a selection, there is a menu entry “*FredoScale*” in the Selection Contextual menu too.

At time of publishing the version 2.0, FredoScale is available in **International English** and **French**. Kind contributors provided translations of version 1.0 for **German** (Tom2), **Italian** (Marco Cosedi) and **Spanish** (Pichuneke), and may update it for version 2.0.

Finally, you can decide to use alternate icons and cursors, if someone publishes any. Image files should be packaged in a folder named “IMAGES_xxx” to be dropped into the subfolder FREDOSCALE_Dir_20.

¹ I will use *Fredo6 Collection* for grouping small scripts, in order not to pollute too much the menu structure

You can modify the default setup for menus and toolbar by configuring the *Default Parameters*:

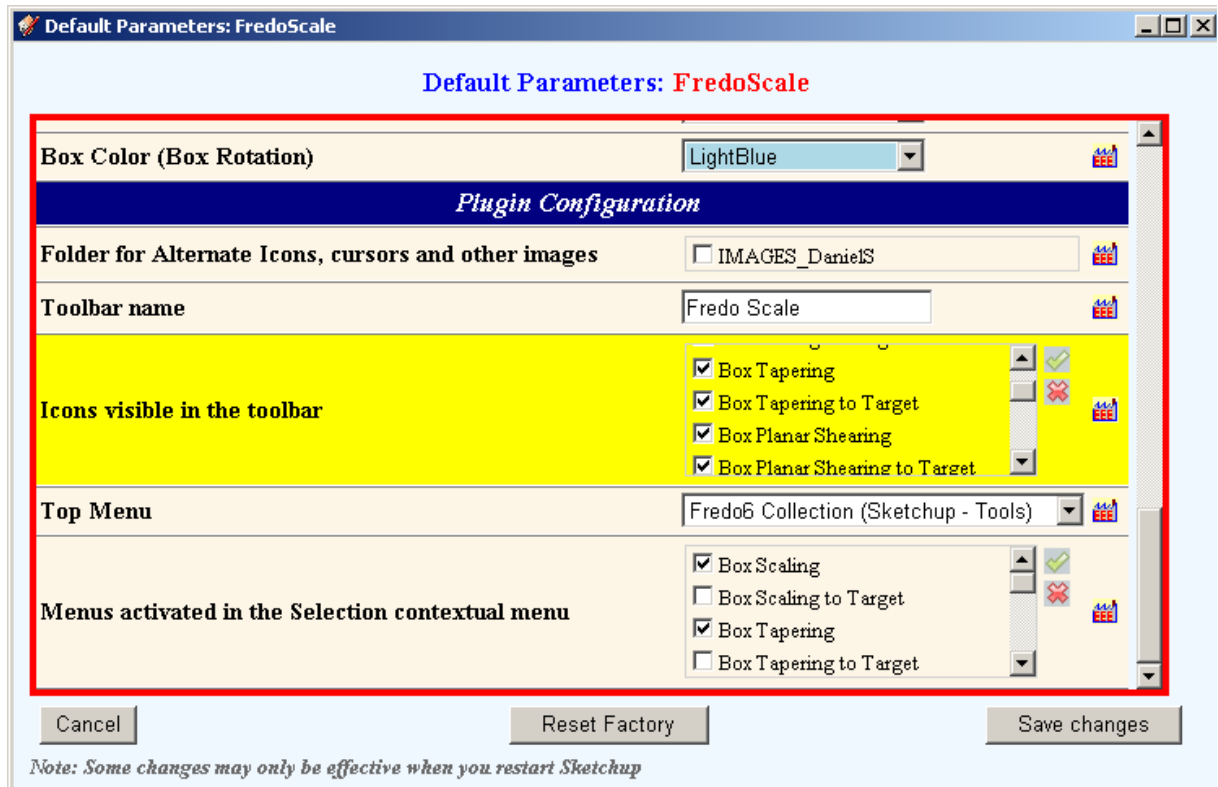

You will also find several other settings which you can change. The parameters are preserved from one session to the next one (the parameter file is stored in the DEFPARAM_Dir folder of the Sketchup plugin directory).

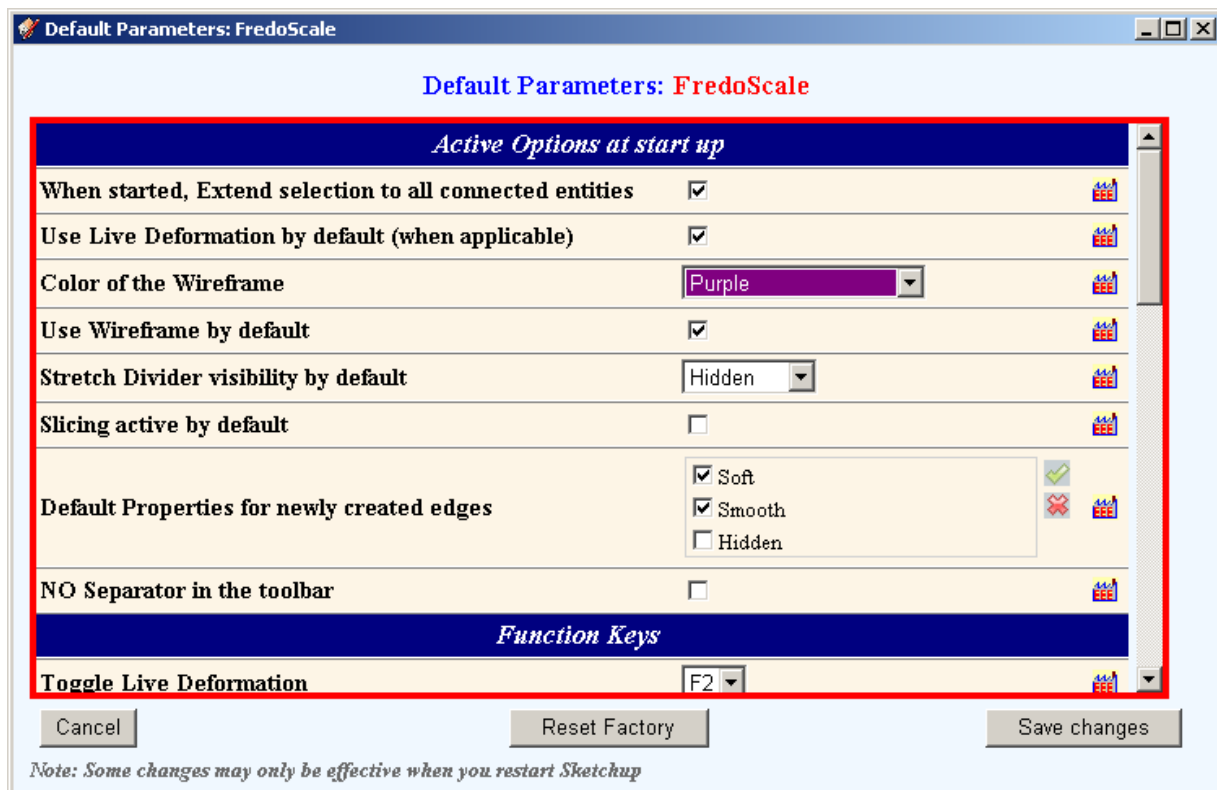

4. Basic Principles

The FredoScale plugin works for **Sketchup versions 5², 6 and 7** (Free and Pro).

1) Free Scaling

FredoScale is a variant of the native Sketchup Scale tool, allowing **free orientation of the scaling box**, instead of using a box always matching the red, green and blue axes of the model. By default, the script will try to find the best fitting box, but you can modify it interactively.

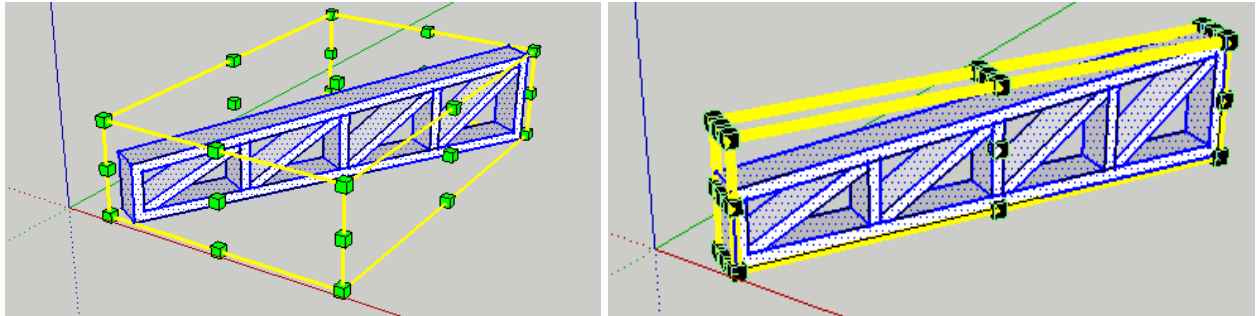

Native Sketchup Scale

Free Scale

Likewise, it is easier to scale a 2D drawing on a face, regardless of its orientation:

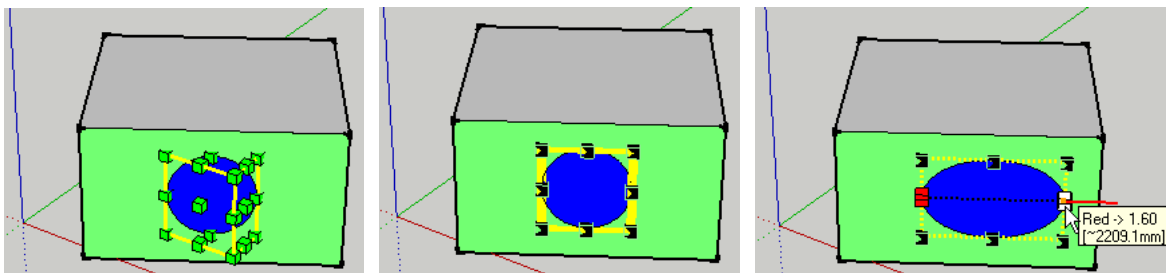

Native Sketchup Scale

Free Scale box

Free Scale deformation

Like the Sketchup native Scale tool, FredoScale works on any selection of objects, made of simple geometry, groups and components. It supports scaling from corners, middle of segments and centers of faces, about the opposite corner or about the scaling box center. Scaling can be uniform or non-uniform. Scales can be entered and modified via the VCB, while scaling the box or right after. The deformation can be shown live, while dragging (although live feedback can also be shown in wireframe only).

There are however a few additional features:

- **you can scale single edges**. This may be useful to do simple tapering,
- you can directly specify the scaling by **setting the target dimensions of the scaling box**,
- you can also **scale the selection by pairing an origin point with a target point** ("*Scale to Target*"). This may help the aficionados of the Push-Pull-Scale method.

² Version 5 must be 5.160 and higher

2) Taper Scaling

The principle is to taper the selection by scaling a face (or an edge) of the scaling box. For instance, with a 3D selection:

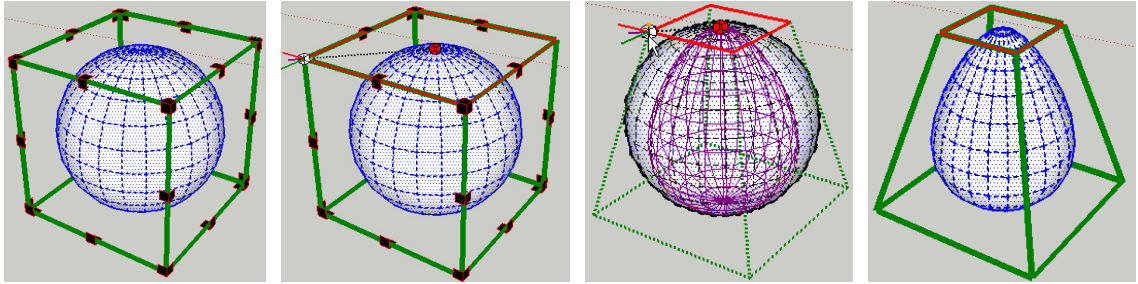

Selection box

Selecting face for tapering

Tapering from center

Sphere → Egg

The same approach works on a 2D selection:

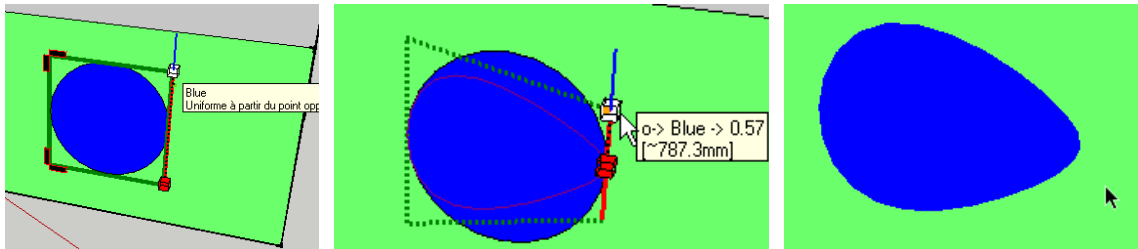

Remember that you can do these tapering transformations (and much more!) with the very powerful plugin **SketchyFFD** by Chris Phillips.

5. Using FredoScale

All Tools functions in 4 steps, noting that Steps 1 and 2 are common to all of them:

- 1) **Selection of the elements to scale or taper** (explicit or implicit)
- 2) **Orientation of the Scaling Box** (if the one computed by default is not satisfactory)
- 3) **Selection of a handle (or pads)**
- 4) **Interactive deformation**, via manipulating the box handles, typing scales in the VCB, entering dimensions or using the “to Target” mode.

1) Selection

Selection is considered valid if it contains at least 1 edge or 1 face, whether at model level or embedded in components or groups.

Like for many Sketchup tools, it supports 2 modes of selection: **Explicit** and **Implicit**

- **EXPLICIT**: **First do the selection, then start the tool.**

The FredoScale or Tapering mode will start directly when you click on the toolbar icon (or select the submenu) if the selection is valid. By pressing **ESCAPE**, you can clear the active selection and go to the IMPLICIT selection mode.

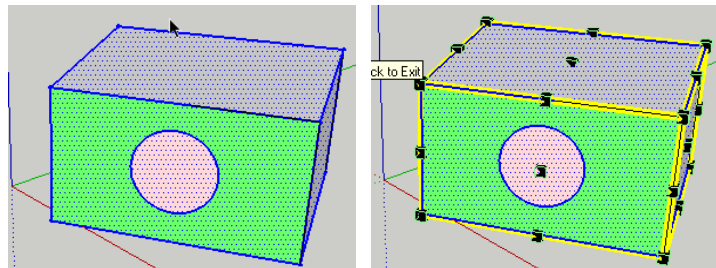

- **IMPLICIT**: **Start the tool with NO active selection, and then select entities by Mouseover; Click when finished.**

The selection is done by Mouse over, like in Sketchup native tools. In addition:

- **Keeping CTRL depressed**, will add / remove to the current selection
- **Toggling SHIFT**, to either select individual faces and edges, or select all their connected elements.

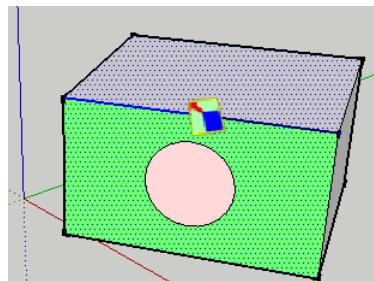

Individual selection mode

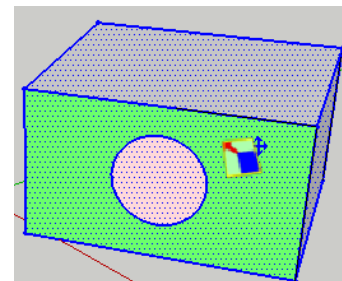

'All-connected' selection mode

Note on Face selection: whether the ‘View ‘hidden’ option is active or not, the selection of one face extends to all neighbor faces that have edge hidden or softened (so you actually select “surfaces”).

2) Orientation of the Scaling box

The initial Scaling box computed tries to reflect the best fit, at least for a given plane:

- **Dimension 1:** single edge or collinear edges (whether contiguous or not). The box is actually a single line.

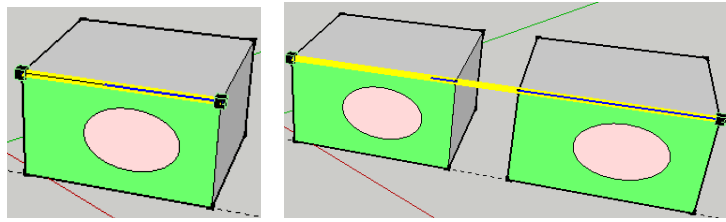

- **Dimension 2:** when all entities are located in the same plane, the scaling box is the best-fitting rectangle. The exact solution is adjusted to reflect symmetries when manageable (issues are for circles and regular polygons).

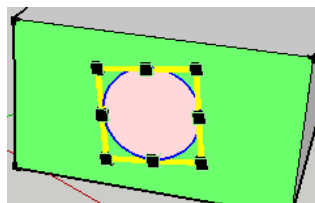

Symmetry in all directions

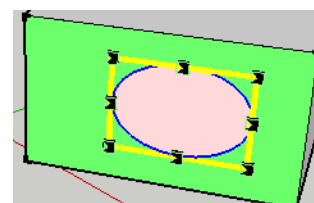

Symmetry in only 2 directions

- **Dimension 3:** the initial scaling box is oriented along the Horizontal Plane (most common case). If your selection is not, then you'll have to adjust this plane.

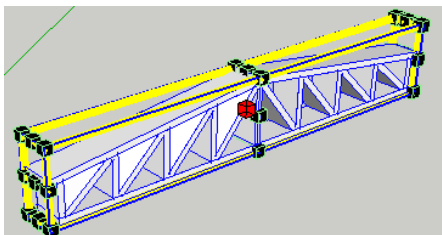

Selection aligned on Horizontal Plane

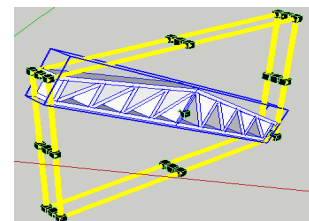

Selection not aligned

Once you have a Scaling Box, you can **change its orientation** by several means:

- **Arrow Keys:** **Up** for model axes, **Left** and **Right** to cycle through the axes of the top-level components, and **Down** restores the initial box.
- **Mouse over edge:** when you move the mouse over edges anywhere in the model, you will notice that they highlight in **orange**. If you click, the box will realign along the selected edge.

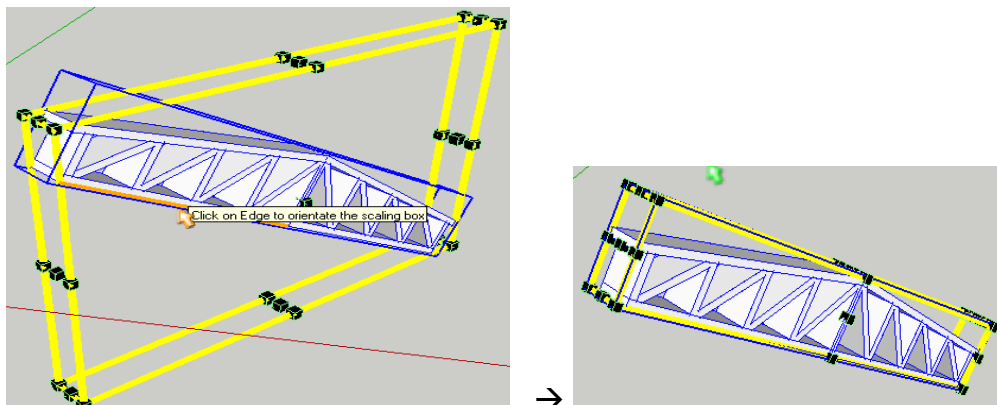

- **Mouse over face:** when you move the mouse over faces anywhere in the model, you will notice that the cursor becomes a **Red arrow**. If you click on the face, then the box will align with the face plane as one of its plane.

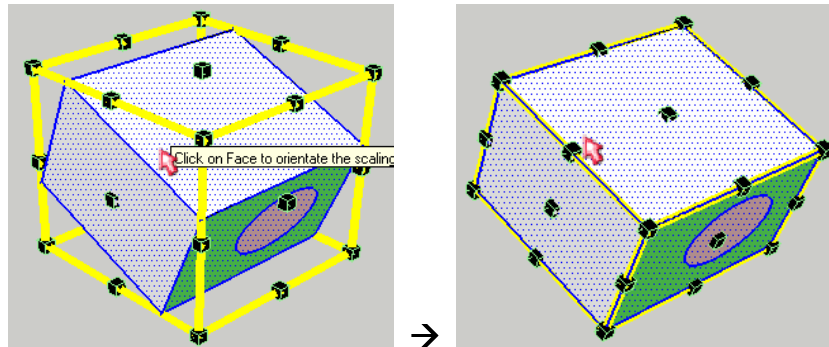

For random 3D orientation, you may have to apply Face and Edge alignments successively.

3) Interactive Free Scale

Once you have the scaling box correctly oriented, you can use it pretty much as the native Sketchup Scale tool. Gently mouse over a handle. It will highlight in White, and the fixed point (pivot) in Red. Local axes are defined for the scaling box and shown at the dragging handle.

The modifiers works in Toggle mode³:

- **CTRL:** select the pivot as the Center or the opposite handle
- **SHIFT:** Uniform / non Uniform deformation for the corner and middle handles

After you selected the dragging handle you can:

- **Drag the handle.** The plugin supports both '**Click down – Drag – Release**' and '**Click – Release – Drag – Click – Release**' modes.
- **Type scale(s) in the VCB,** as float numbers, positive or negative. Note that the plugin supports both ',' and '.' as the decimal separator, regardless of your system settings.
- **Call the Box dimension dialog box,** by pressing **TAB**. This allows you to set the dimensions, and therefore the scales, in the directions allowed by the type of handle you selected.

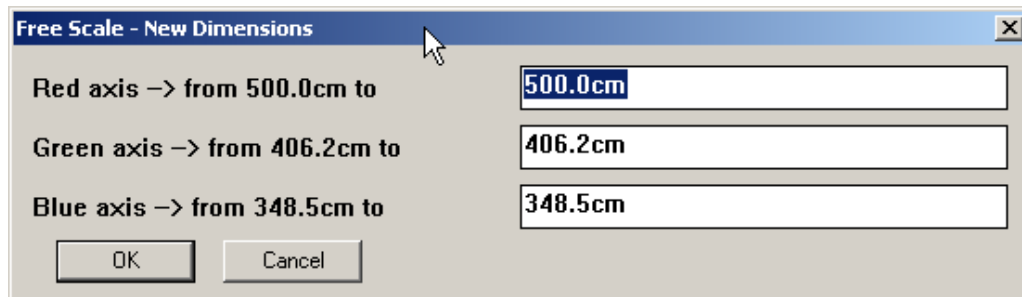

³ Unlike native Sketchup Scale tool, where Ctrl and Shift keys are active only when depressed

By default, the scaling deformation is done interactively on the selection. However, you may want to disable this feature in order to better use inferences when moving the selected handle:

- **F2**: toggle 'live' deformation when dragging.
- **F3**: toggle 'wireframe' on or off, when there is no live deformation.

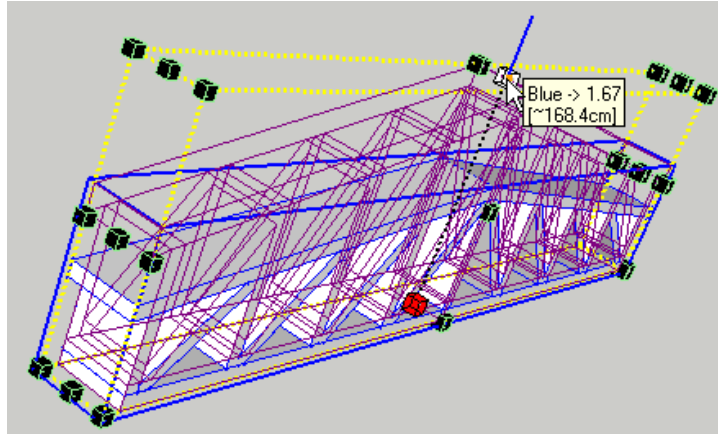

After you have done a deformation, by whatever method, you can still modify the scales by the same methods (dragging, VCB, dimension dialog box). Note however that the scale is kept to its last value for the handle pair you last used (otherwise it is reset to 1.0).

Finally, all commands and short cuts are available via the contextual menu.

4) Target Mode

This is another way to specify the scaling factor(s). The idea is that **you visually specify the deformation as the transformation that would bring an Origin point to a Target point.**

There are two main ways to invoke the Target mode.

- 1) **You invoke it via the menu or the icon⁴**



- 2) **You double-click on a scaling handle.** This works in toggle between Scale to Target and Free Scale.

The deformation box is displayed in a different color.

The first action is to select the Origin, by moving the **Green Cross** and click. Then, you move it to the target, shown as a **Red Cross**. The Origin and Target can be located anywhere in the model.

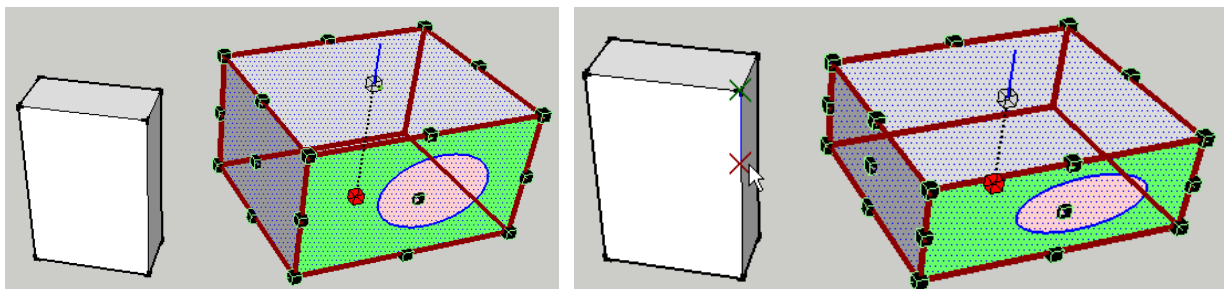

⁴ if you have added it to the toolbar

Note however that there are regions where the Origin is forbidden, usually close or 'behind' the pivot handle (as these regions are never deformed in the scaling).

The placement of the target supports inference from the origin:

- **Arrows** for locking on axes of the scaling box
- **Shift** to lock in current direction (toggle key)
- **Stickiness** to axes, collinear and perpendicular to edges

In addition, you can type the **distance** in the **VCB**.

5) Taper Scale

While the selection and box orientation are similar to Free Scale, there are differences in specifying the deformation. Remember that the tapering is done by **scaling one face of the box**, and apply it to the selection.

First, the scaling box does not show cubic handles but **small pads** on each face.

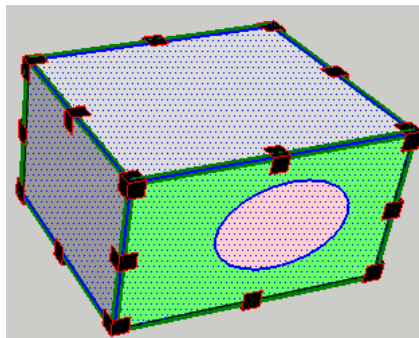

The principle is that you carefully mouse over the pads to select the face to scale and the dragging pad (since the same handle corresponds to 2 or 3 faces).

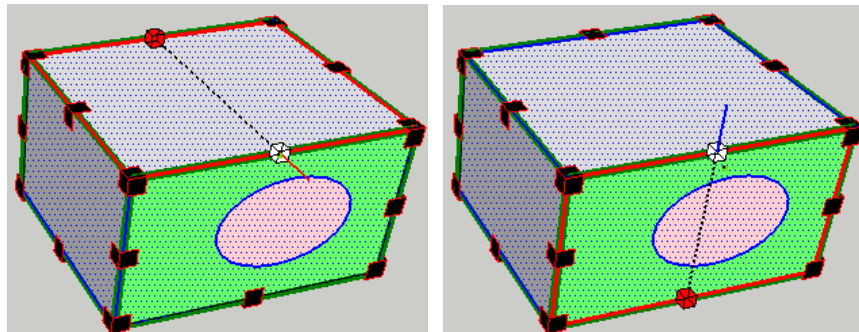

From there, you use the handle to scale the selected face. You can use **CTRL** to specify deformation about the center or opposite pad, and **SHIFT** to enable uniform or non-uniform scaling. You can also set the scale by the box dimension (using **TAB**)

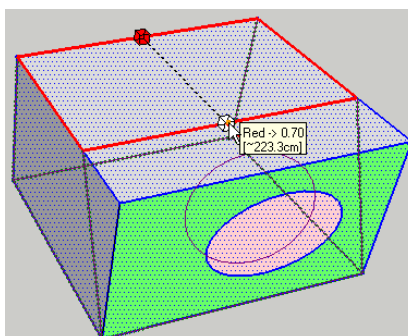

Tapering deformation

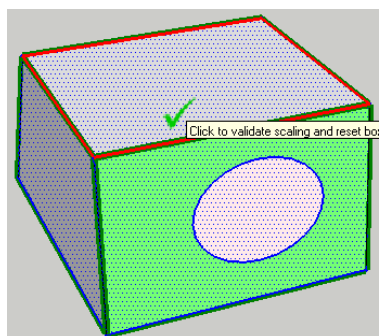

Validation stage

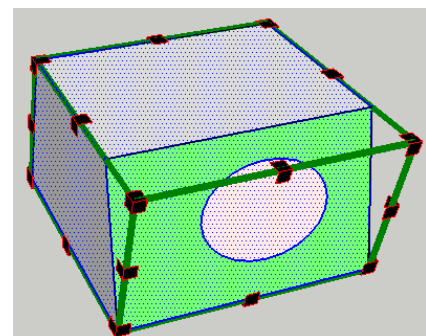

Refresh box after validation

While dragging the pad, only the box is deformed live. The model deformation is shown optionally in wireframe, but the model will be deformed only when you finish dragging.

When the deformation is done, the cursor is shown as a green Check mark. In this stage, you can either continue dragging, or specify the scale(s) in the VCB. If you simply click, then, the new scaling box will be computed.

In 2 dimensions, you have to select edges of the rectangle. The pads have a different shape, but the principle remains the same.

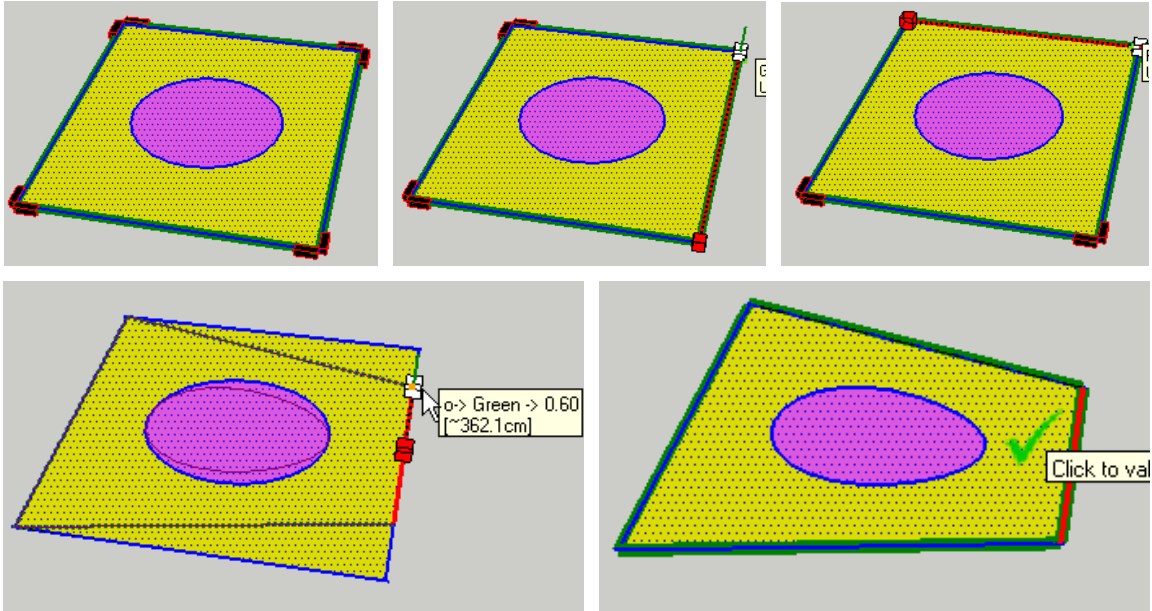

Note finally that **in dimension 1**, Taper Scale is equivalent to Free Scale.

6) Taper to Target

Like for Scale to Target, Taper Scale has a mode that allows specify the deformation by matching an origin and a target point.

You can call it via the menu or icon, if enabled, or by double-clicking on a pad.

The behavior is the same as for Scale to Target, as Taper Scale is finally just equivalent to scaling a face (or an edge) of the box, using the Free Scale method.

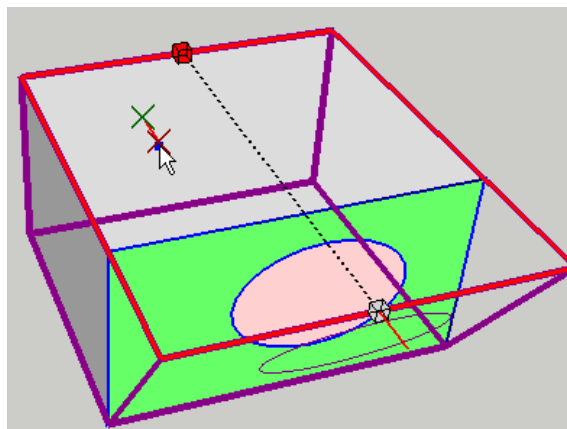

6. Additional Features

A few features worth noticing:

- 1) **Exiting the tool:** at any stage, if you move the cursor outside any element of the model, it will display a **Green Arrow**. If you click, you will exit the tool.

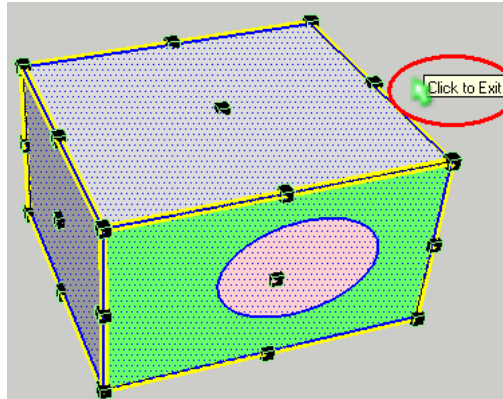

- 2) **Escape:** this key is used contextually to go to the previous state, like in the native Sketchup tools.
- 3) **Undo:** it is supported during the scaling operations. The scaling box is recomputed on the fly. It may appear asynchronously.
- 4) **Formulas in dimensions dialog box:** you can type mathematical formulas and specify units. For convenience, the decimal separator can be the comma or dot indifferently. If you do not specify a unit, then the current model unit is assumed. However, the convention is that multiplying and dividing factors are always placed AFTER the length. For instance “2’ ½ * 2.5” is valid, whereas “2 * 3cm” is not.

For instance, the following will result in 405 cm.

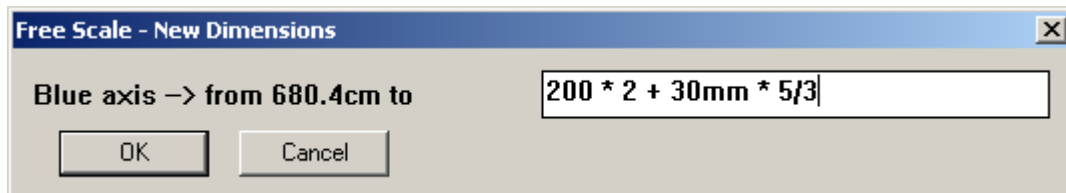

Architectural units are supported.





- 5) **Specifying several scales in the VCB:** for non uniform scaling you may have to enter up to 3 numbers (like in the native Sketchup Scale tool). The valid separator is either a **space** or a **semi-column** (;'). The decimal separator can be the comma or dot indifferently. You can use a formula too, but you must NOT use spaces within your formula.

7. Plugin Configuration











1) Default Parameters

Via the menu “*Default Parameter...*”, you can specify a few settings. I hope the dialog box is self-explanatory:

- 1) **Visual parameters**, mainly colors and selection mode

| <i>Active Options at start up</i> | | |
|--|-------------------------------------|---|
| When started, Extend selection to connected entities | <input checked="" type="checkbox"/> |  |
| Color of the Scaling Box (Free Scale) | Yellow |  |
| Color of the Scaling Box (Free Scale to Target) | DarkRed |  |
| Color of the Scaling Box (Taper Scale) | Green |  |
| Color of the Scaling Box (Taper Scale to Target) | DarkMagenta |  |

- 2) **Plugin settings**, about the menu and tool bar configuration, as well as the alternate icons (if any provided).

| <i>Plugin Configuration</i> | | |
|--|---|--|
| Folder for Alternate Icons, cursors and other images | <input type="checkbox"/> IMAGES_Second |  |
| Toolbar name | Fredo6 Collection |  |
| Icons visible in the toolbar | <input checked="" type="checkbox"/> Free Scale <input type="checkbox"/> Scale to Target <input checked="" type="checkbox"/> Tapering Scale <input type="checkbox"/> Tapering to Target |     |
| Top Menu | Fredo6 Collection (Sketchup - Tools) |  |
| Menus activated in the Selection contextual menu | <input checked="" type="checkbox"/> Free Scale <input type="checkbox"/> Scale to Target <input checked="" type="checkbox"/> Tapering Scale <input type="checkbox"/> Tapering to Target |     |

IMPORTANT: Default parameters are stored in a file (*FredoScale.def*) which is located in a special subfolder **DEFPARAM_Dir** of the Sketchup Plugin folder (and thus not in FREDOSCALE_Dir_10). This allows your default parameters to survive when you upgrade to newer versions.

2) Documentation and Support

There are menu entries that will open the PDF documentation, and the web site where the Plugin is discussed.

3) Language Translation

As a feature provided by the shared Library LibFredo6, it is now possible to translate the plugins in most languages via external files. The translation **MUST** be done from within the tool, but the result is stored in individual files per language (here *FredoScale_xx.lang*, where xx is the language code). The whole translation process is documented separately in the manual related to LibFredo6.

8. Known Limitations – Caveats - Performance

1) Bugs

- **In some situation, the initial best fitting box is not correct** (so you need to manually adjust the direction). This may be due to problems with rounding and Sketchup approximation when testing parallel vectors. I'll try to fix it in a next version.

2) Caveats and Limitations

- **You must NOT modify the selection during the scaling operations** (via Ctrl-A or Ctrl-T for instance). Unexpected result if you do.
- **The FredoScale tool does NOT do 'Smart Scaling' with Dynamic components.** This is because the scaling method available in the Sketchup API does not support it, and there is no other API yet.
- **Taper Scale is slightly 'destructive'**, in the sense that:
 - It makes 'unique' all components and groups selected
 - It explodes all curves present in the selection

Note however that the plugin just applies transformation to the model, meaning that all materials, attributes and element hierarchy are preserved (i.e. the plugin does not 'reconstruct' the model).

In all cases, it is highly recommended that you save your model prior to perform this transformation on complex models. In some occasions, the Undo can generate a bug splat.

- **On edges or faces, FredoScale always forces a line or rectangle scaling box.** In native Sketchup Scale tool, when the lines or face are not aligned with the axes, you get a 3D box which allows making more transformation in 3D space.
- **In interactive deformation mode via dragging handles, you cannot scale down the model below a factor of 0.1.** I noticed strange behaviors when doing it. Instead, use the VCB or the Dimension dialog box for setting smaller scales.

3) Performance consideration

- **The time to load the plugin is indicated in the "About..." dialog box.** It should be fast, less than 100 ms. Please check it and report if you find an abnormal time.
- **Free Scale** is sensitive to the complexity of the model to compute the initial Scaling box. However, once computed, the change of orientation should be fast, and the interactive scaling behaves more or less at the same speed as the native Sketchup Scale tool.
- **Taper Scale** requires more computations for the transformation. This is why I did not make it interactive visually, except in wireframe. In practice, however, you would not taper a very complex model in one shot.